

MATERIAL: ALUMINUM

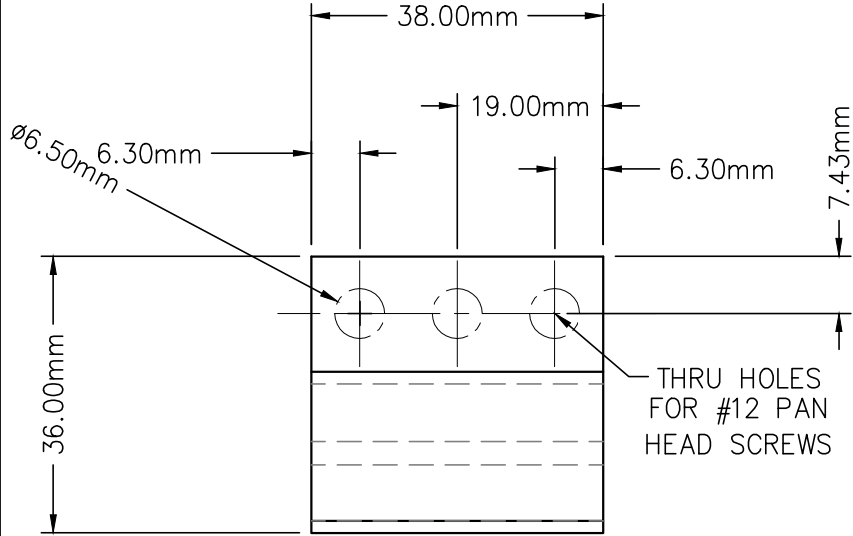

1  
01 FRONT VIEW SCALE 1:1

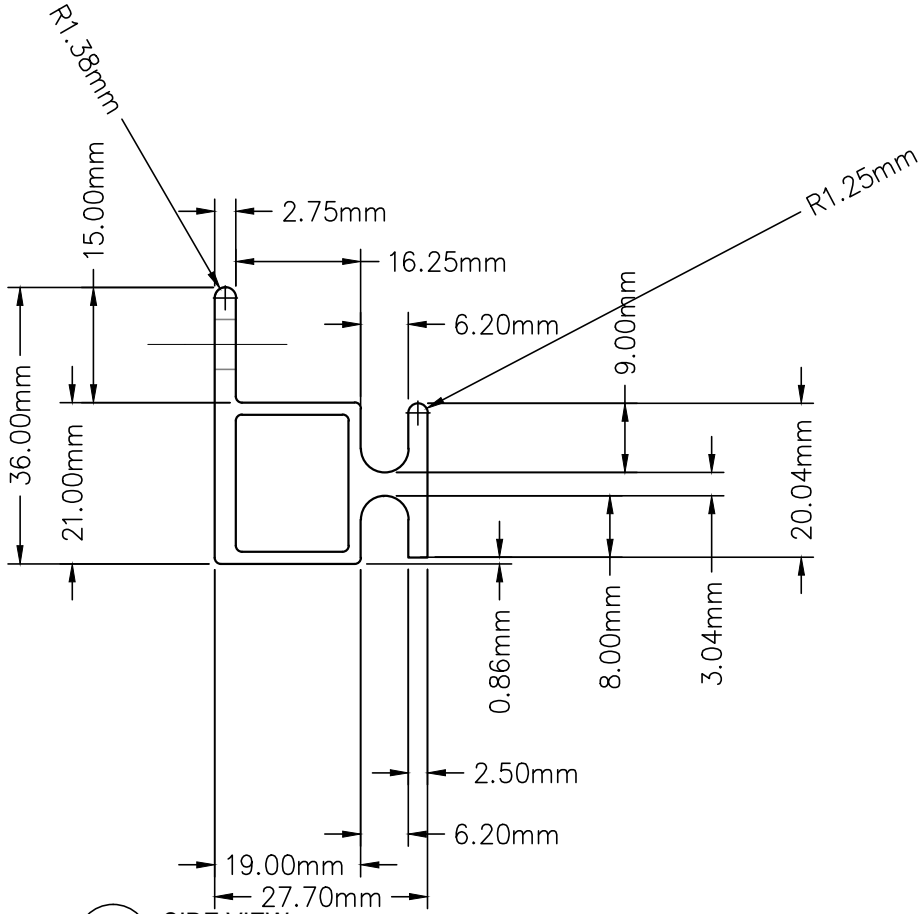

1  
01 SIDE VIEW SCALE 1:1

REVISED BY: WSR	REVISION NO.: <b>1</b>	PAGE NO.: <b>01</b>	<b>DASSO</b> 115 C Twinbridge Drive Pennsauken, NJ 08110 www.TesoroWoodsInc.com (609) 585-3100 ©2013	PRODUCT: <b>SIDING SHEATHING CLIP</b>	NAME:
REV. DATE: 12/31/13				TITLE: <b>ELEVATION AND SECTION</b>	LOCATION:
SAP #				DRAWN BY: WSR DATE: 8/5/13 SCALE: AS NOTED CONTACT:	
<b>9_15 D</b>				FILE: 9_15 DASSO CLIP PROFILES.DWG PRINTED: 12/31/2013 5:08 PM	SHIP DATE: